

OWNER'S MANUAL

English

SERIE: **"FALCON"**

MODELS: **F380** **F420** **F480**
 F380H* **F420H*** **F480H***

2357D.01

Base version: **F380** **F420** **F480**

Tender Deluxe version: **F380T** **F420T** **F480T**

H* – boat tube is made of HYPALON (Du Pont registered trademark) coated fabrics.

CONTENTS:

DANGER LEVELS	3
INTRODUCTION	3
IDENTIFICATION PLATE	4
SAFETY REGULATIONS	5
BEAUFORT Wind Scale and Corresponding State of the Sea, After Few Hours of Wind, Away From the Coast.	6
Boat Design Categories	6
REMEMBER FIRE DANGER ALWAYS	7
TECHNICAL SPECIFICATIONS	8
COMPLETE SET	9
GENERAL VIEW of the BOATS	10
STEERING CONSOLE	
Steering Console for Tender Deluxe Version	12
Tender Container for Tender Deluxe Version	13
Inflation/deflation boat tube	14
PREPARATION FOR EXPLOITATION	15
DRAIN SYSTEM	15
FUEL SYSTEM	16
MAINTENANCE	18
OPERATING REGULATIONS	18
REBOARDING MEANS	23
WARNING SIGNS AND LABELS	24

CE Certification and Main Features

The CE marking indicates that the inflatable boat meets the requirements of the Recreational Craft Directive 2013/53/EU

Name of Manufacturer:

BRIG Ltd.
Lozovskaya 88,
Dergachy 62303
Kharkovskaya obl.
UKRAINE
www.brig-ribs.com

Certifying Body:

INTERNATIONAL MARINE CERTIFICATION
INSTITUTE
Rue Abbe Cuypers 3 / B-1040 Bruxelles / Belgique
Notified Body : 0609
www.imci.org

DANGER LEVELS.

The manual contains warnings, identified as follows:



A note like this indicates that there is serious risk that is likely to cause death or permanent serious injury, if appropriate precautions are not taken.



A note like this indicates the existence of risk that may cause death or injury, if appropriate precautions are not taken.



A note like this indicates reference to the application of safety or environmental protection practices, or draws attention to unsafe behaviour that might cause injury to persons or damage to the craft, its components or the environment.

INTRODUCTION.

This manual was written to help you using your boat safely. It contains information of the boat, its equipments (supplied or installed), operation and maintenance.



Before using your boat, read the **MANUAL** carefully and ensure that you have understood all the procedures it describes. Before taking command of your boat, be sure to have acquired experience and confidence in its operation.

IDENTIFICATION PLATE.

Builder's Plate:

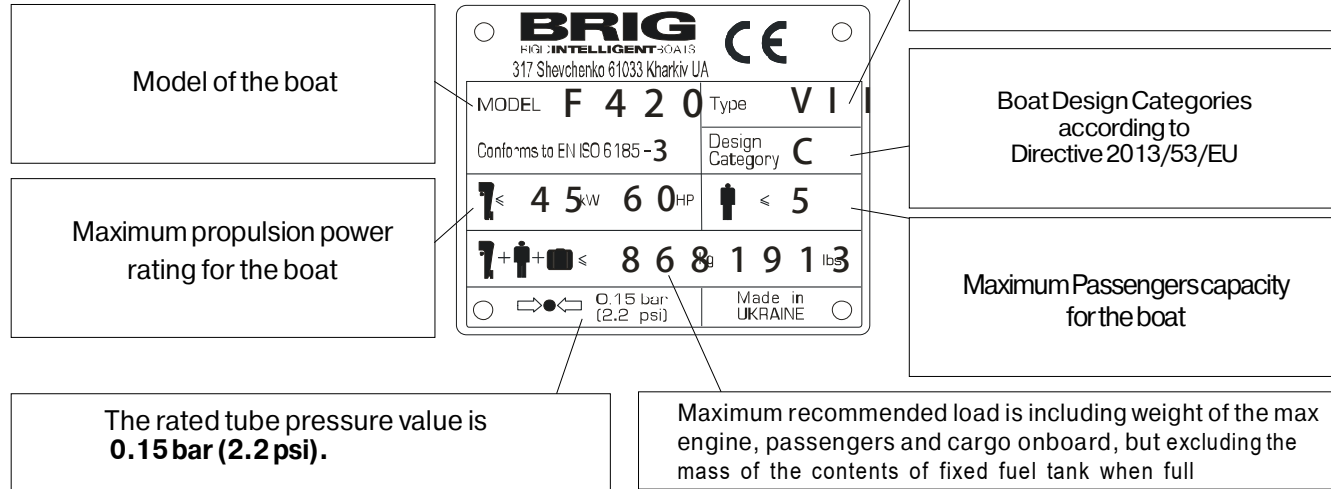

Plate with identification number:

UA-QRK12345A000





ATTENTION

It is fundamental for the plates to be aboard the boat, since they are only form of recognition and identification. Without them the boat does not comply with the legislation in effect. The plates must never be removed. Any tampering or removal not authorised by the manufacturer is the full responsibility of the owner.

SAFETY REGULATIONS.

This manual contains recommendations and basic rules of conduct for using the boat in complete safety. Although it is not possible to offer safety information for all potential situations, in general it is recommended that you:

	Regularly check which safety requirements are in force.
	Maintain the boat and the onboard plants in optimum condition.
	Have the boat inspected by the dealer where it was purchased or by an authorised machanic at least once every year for your own safety and for maintaining the guarantee.

	Always check weather and seagoing conditions before setting out. For safe navigation, compare the design category of your boat with the table below.
	When the tank is installed by the yard, the plant is prepared with a ground plait. The installation of the motor MUST FORESEE A PLAINT CONNECTION to the boat ground plait. Failure to connect (or failed maintenance) can result in the tank perforaiting leading to a serious risk of fire / explosion caused by leaking fuel.

	<p>Max number of transportable persones is referred to an established weight of 75 kg per person (ISO 6185), so always make reference to total maximum transportable waight.</p> <p>The max weight of the installable motors indicates the maximum overall weight applicable on the stern board, including any emergency motors. NEVER exceed the stated value.</p>
---	--

BEAUFORT Wind Scale and Corresponding State of the Sea, After Few Hours of Wind, Away From the Coast.

Force	Denomination	Knots	Km/h	m/sec	State of the sea and wave height in meters	
0	Calm	<1	<1	0-0.2	Calm	0
1	Light Air	1-3	1-5	0.3-1.5	Calm	0
2	Light Breeze	4-6	6-11	1.6-3.3	Almost calm	0.2
3	Gentle Breez	7-10	12-19	3.4-5.4	Almost calm	0.2
4	Moderate Breeze	11-16	20-28	5.5-7.9	Small waves	0.5
5	Strong Breeze	17-21	29-38	8.0-10.7	Large waves	1.25
6	Fresh Wind	22-27	39-49	10.8-13.8	Large waves	2.0
7	Strong Wind	28-33	50-61	13.9-17.1	Very large waves	2.5
8	Gale	34-40	62-74	17.2-20.7	Rough sea	4
9	Strong Gale	41-47	75-88	20.8-24.4	Very rough sea	6
10	Storm	48-55	89-102	24.5-28.4	Heavy	9
11	Violent Storm	56-63	103-117	28.5-32.6	Very heavy	14
12	Hurricane	64 and over	118 and over	32.7and over	Stormy	14 and over

Boat Design Categories :

Design category	Wind force (Beaufort scale)	Significant wave height
"A" - "Ocean"	exceeding 8	exceeding 4
"B"- "Offshore"	up to,and including, 8	up to,and including, 4
"C"- "Inshore"	up to,and including, 6	up to,and including, 2
"D"- "Sheltered waters"	up to,and including, 4	up to,and including, 0.3

NOTE: **The significant wave height** is the mean height of the highest one-third of the waves, which approximately corresponds to the wave height estimated by an experienced observed. Some waves will be double this height.

REMEMBER FIRE DANGER ALWAYS.

Fire may be caused by:

Crew negligence when smoking, the presence aboard of flammable liquids, electrical contacts, propulsion motor, errors in fueling, or if maintenance has not been performed as required.

Once again, it is important that the crew behave correctly and that the boat is kept in order to avoid serious damage to it and to persons.

 <p>WARNING</p>	Easily flammable products must not be kept aboard.
---	--

 <p>DANGER</p>	BATTERY: the battery may cause sparks or explosions. It must be stored in an appropriate container, easily reached and well aired, AWAY FROM FUEL OR INFLAMMABLE PRODUCTS . Periodically check that the clips are tight and protect them with appropriate insulation in order to prevent sparks or the spread of current.
--	--

However, if a fire does occur aboard, stop motor, disconnect the batteries immediately, check to see if it is an electrical component or any case a small-scale fire that does not involve flammable liquids, in which case use a suitable fire extinguisher to try and put the fire out completely.

 <p>WARNING</p>	Extinguisher or any other fire-fighting equipment must not be kept in compartments with key lock, but in easily accessible and clearly indicated locations.
	Extinguisher or any other fire-fighting equipment should be checked periodically and replaced with the same or superior types if expired or inefficient .

 <p>DANGER</p>	Equip the boat with fire-fighting equipment before launch and use.
--	--

TECHNICAL SPECIFICATIONS.

The basic parameters and dimensions of the boats comply with the data specified in the following table. All dimensions measurements indicated have a tolerance of +/- 3%, weight measurements indicated have a tolerance of +/- 5%.

Parameter	F380 (F380H)	F420 (F420H)	F480(F480H)
Length (without engine)	3.80 m	4.20 m	4.90 m
Width	1.90 m	1.90 m	2.15 m
Height (max. with steering console)	1.10 m	1.10 m	1.15 m
Inflatable tube diameter, max.	0.48 m	0.48 m	0.50 m
Cockpit dimensions:			
- length	2.80 m	3.20 m	3.70 m
- width	0.90 m	0.90 m	1.15 m
Deadrise angle on transom	23°	23°	21°
Deadrise angle in middle section	24°	24°	24°
Transom height	500mm	500mm	500mm
Number of independent air-tight chambers	3	4	5
Nominal pressure	0.15 bar (2.2 psi)	0.15 bar (2.2 psi)	0.15 bar (2.2 psi)
Passengers capacity	5 (6**)	5 (7**)	6 (9**)
Recommended engine power	30 hp (22 kW)	50 hp (37 kW)	60 hp (45 kW)
Maximum engine power	50 hp (37 kW)	60 hp (45 kW)	75 hp (56 kW)
Maximum engine weight	183kg	183kg	210kg
Engine shaft length	20" (Long)	20" (Long)	20" (Long)
Fuel tank capacity (if applicable)	33L	33L	33L
Weight of fully empty boat (without: steering console, seat, fuel, engine)	115kg	125kg	190kg
Weight of empty boat with equipments (with steering console, with seat, without engine, without fuel)	155kg	170kg	240kg
Maximum load capacity of fully empty boat (ISO method)	850kg	950kg	1200kg
Displacement in Light Craft Condition (LCC)	350kg	365kg	465kg
Maximum total load (ML)	615kg	710kg	925kg
Maximum recommended load*	773*kg	868*kg	1110*kg
Loaded displacement mass (LDC)	965kg	1075kg	1390kg

*Maximum recommended load is including weight of the max engine(s), passengers and cargo onboard, but excluding the mass of the contents of fixed fuel tank when full

**For American market only

COMPLETE SET for Base and Tender Deluxe versions for F380 F420 F480.

No		Base	Tender Deluxe
1.	Inflatable boat	+	+
2.	Front step-plate with navigation lights	+	+
3.	Hard tube ends	+	+
4.	Front removable cushion	+	+
5.	Foot pump	+	+
6.	Paddles	+	+
7.	Set of spare parts and repair kit (coated fabric for repair, glue set for repair)	+	+
8.	Kit bag	+	+
9.	Owner's manual	+	+
1.	Tender Luxe Console	-	+
2.	Steering wheel, steering system with cable	-	+
3.	Bolts for console installation	-	+
1.	Tender Container	-	+
2.	Bolts for container installation	-	+
	Optional equipments		
1.	Overall cover	+	+
2.	SeaDek	+	+
3.	Suntop	+	+
4.	Lifting Slings	+	+
5.	Fuel system	-	+

Note. Perfection of the design and improvement of quality of our products is the fundamental production policy of our company. Therefore, alternations may be made to the complete set (and as the components become available).

GENERAL VIEW of the BOATS.

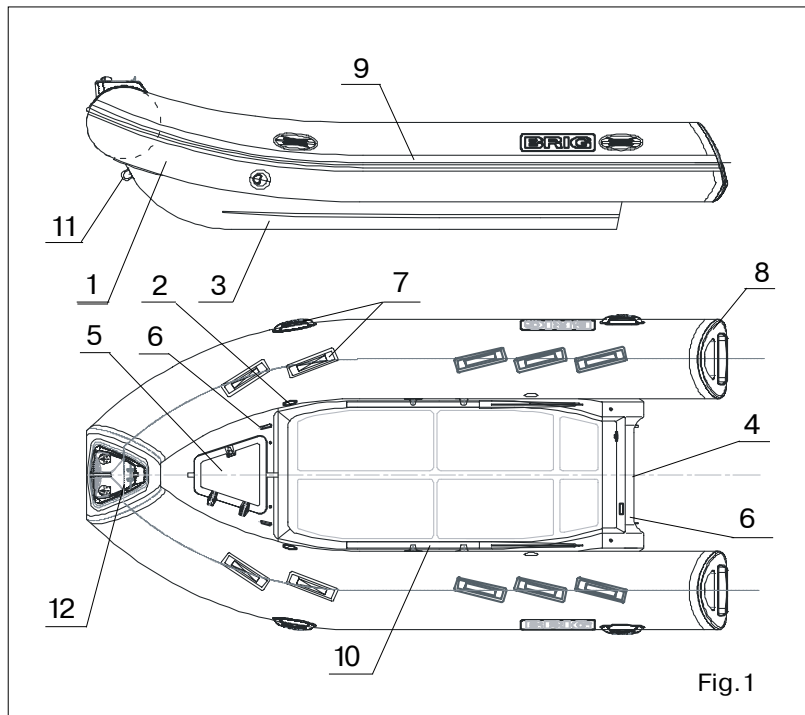

BASE version Boat General View (see Fig. 1).

- 1 - Inflatable tube
- 2 - Inflation valves
- 3 - Rigid bottom with transom
- 4 - Outboard engine mounting plate
- 5 - Bow compartment
- 6 - Lifting eyes
- 7 - Handles
- 8 - Rigid end of the tube
- 9 - Rubbing strake
- 10 - Oars
- 11 - Towing bow eye
- 12 - Front step-plate

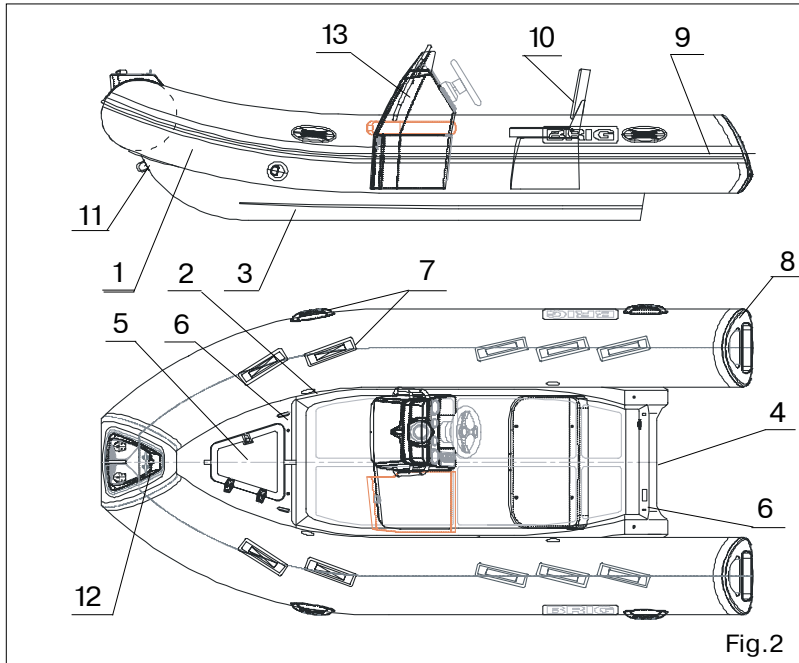

TENDER DELUXE version Boat General View (see Fig.2).

- 1 - Inflatable tube
- 2 - Inflation valve
- 3 - Rigid bottom with transom
- 4 - Outboard engine mounting plate
- 5 - Bow compartment
- 6 - Lifting eyes
- 7 - Handles
- 8 - Rigid end of the tube
- 9 - Rubbing strake
- 10 - Tender container with seat
- 11 - Towing eye
- 12 - Front step-plate
- 13 - Steering console

STEERING CONSOLE.

Steering Console for Tender Deluxe Version.

The Steering console consists of the following main components (Fig.3):

- 1 - console body, that comprises the overhead part , hinged with lower part .
- 2 - cushion;
- 3 - lock;
- 4 - instruments (compass, speedometer, fuel gauge etc.)
- 5 - windscreen;
- 6 - handrail
- 7 - steering wheel

Reliably fix the console by means of the bolt M8 and washers to the deck boat.

You can use inside compartment of the console as locker. Also you can dispose fuel tank inside console.

In this case you must fixed safely fuel tank by belt.

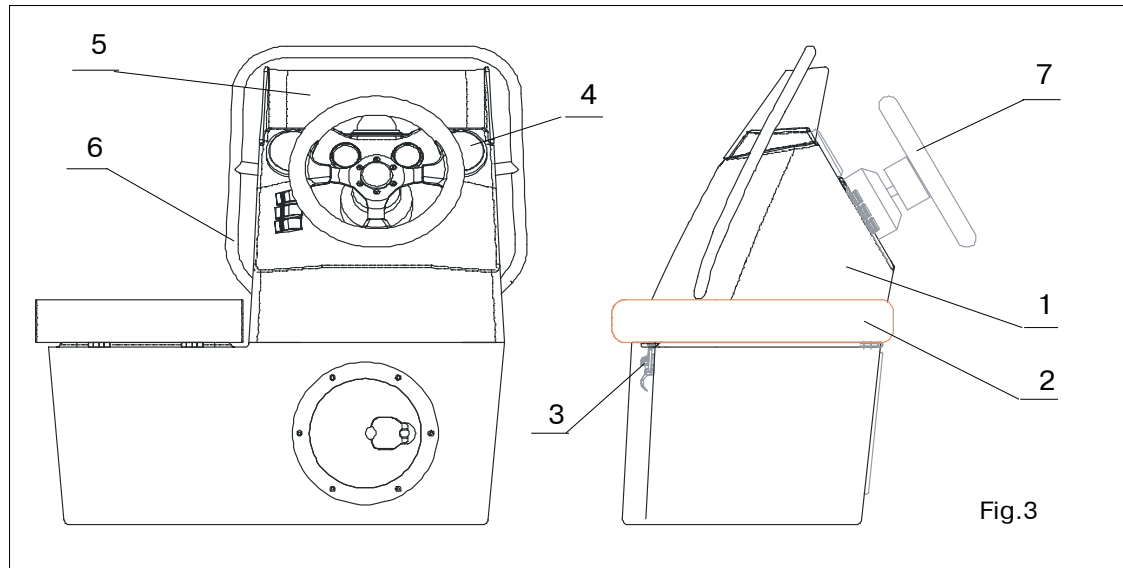

Tender Container for Tender Deluxe Version.

Tender Container is intended for placing of two passengers and for installation of storage battery, oars etc.

They may be mounted on the rigid deck of the "BRIG" boats Tender Deluxe versions and other boats.

Tender Container includes: the locker, soft seat and lock to fixing the seat (see Fig.4).

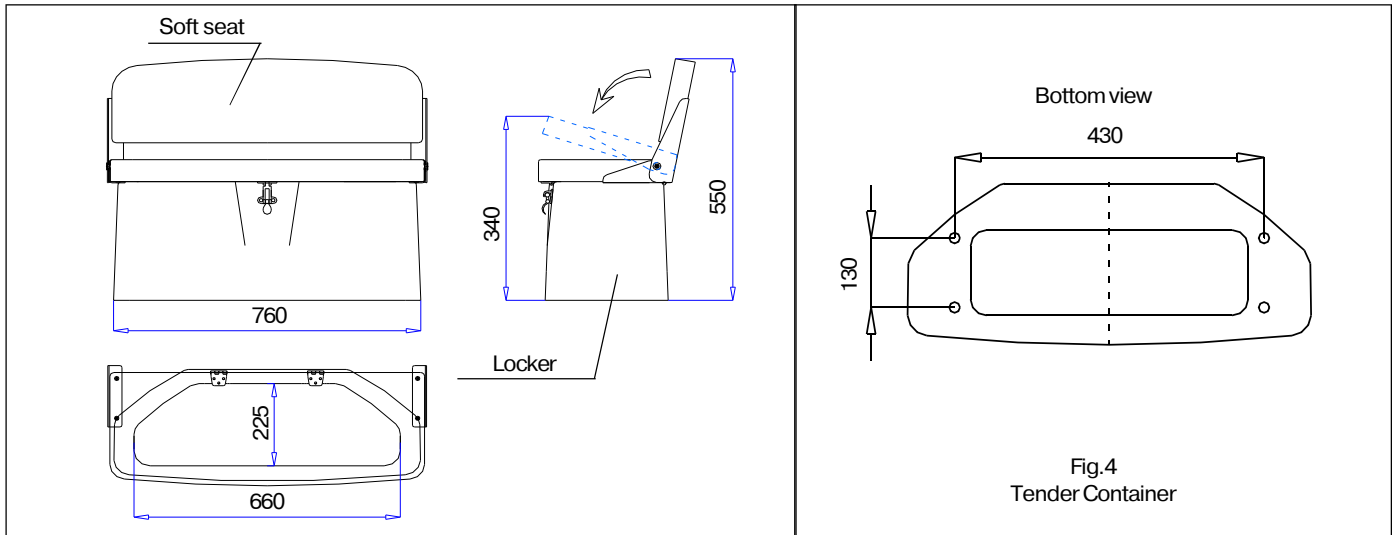

In order to install the container to the BRIG boat perform the next operations (see Fig. 5):

- hinge out the seat;
- fix the container by means of the bolt M8 and washers to the deck boat;
- replace the seat.

Inflation/deflation boat tube.

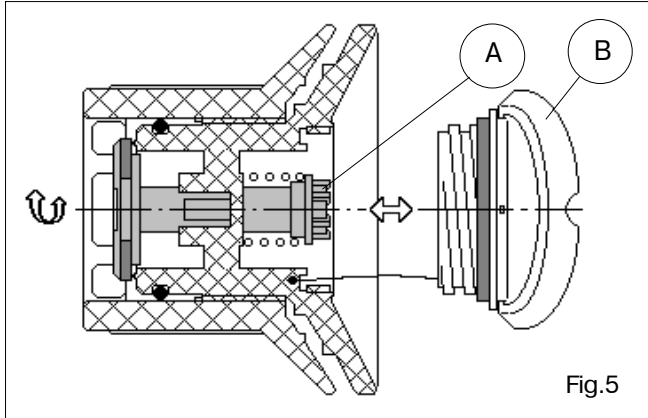

The inflation valve (see Fig.5) has two positions of sliding part A corresponding to its two conditions (modes):

- sliding part A is withdrawn - operation condition of the valve (compartment air filling mode);
- sliding part A is recessed - valve in condition "OPEN" (compartment air discharge mode).

In order to switch the valve over from one condition to another, just press sliding part A with your finger to turn it by 90 degrees in any direction until it is fixed.

Prior to begin the compartment filling process set all valves in the operating condition. On completion of filling close the valves with bonnets B (rotate them clockwise).

In order to discharge air from the compartments, open the valves (by counterclockwise rotation) and switch the valves over into condition "OPEN".



Do not use compressors and/or other types of inflating equipments not approved by the boat builder.

Check tube pressure before every navigation.

The rated pressure value is 0.15 bar (2.2 psi).

If the tube pressure more than nominal, deflate the compartments slightly. Boat exploitation with board pressure more than nominal decreases boat service life.



Board air chambers are hermetical if they keep own form during 8 hours. In this case:

- primary pressure has to be nominal;
- input valves openings have to be tightly closed by caps.

PREPARATION FOR EXPLOITATION.

In order to set the boat in the operation condition perform as follows:

Unfold the inflatable balloon.

Apply the foot pump to fill the afterbody of the compartments with air to the pressure being slightly below its rated value (the balloon will be completely straightened). Then fill the forebody compartment with air up to the rated pressure.

The rated pressure value is 0.15 bar (2.2 pci).

On completion of filling close the valves with bonnets B (rotate them clockwise), (look before).

Assemble the oars by entering the removable parts with blades into the locks until the click. Make use of the holes provided in the oar handles to set the oars into the rowlocks with the blades being faced to the aft. Secure the oars in the holders.

When mounting the outboard engine make sure that it is reliably fixed to the transom. In addition, take every precaution to avoid any contacts of the fuel with the boat surfaces.

DRAIN SYSTEM.

1 - Drain valve for cockpit water
(see Fig.6)

2 - Drain valve for bilge water

It is dangerous to pretend to be an expert. This may cause damages. Refer to expert and authorized specialists for all types of maintenance and repair.



Check before navigation that that the drain valve for bilge water is closed by plug. Open to pour out the bilge water (! ashore ONLY !)

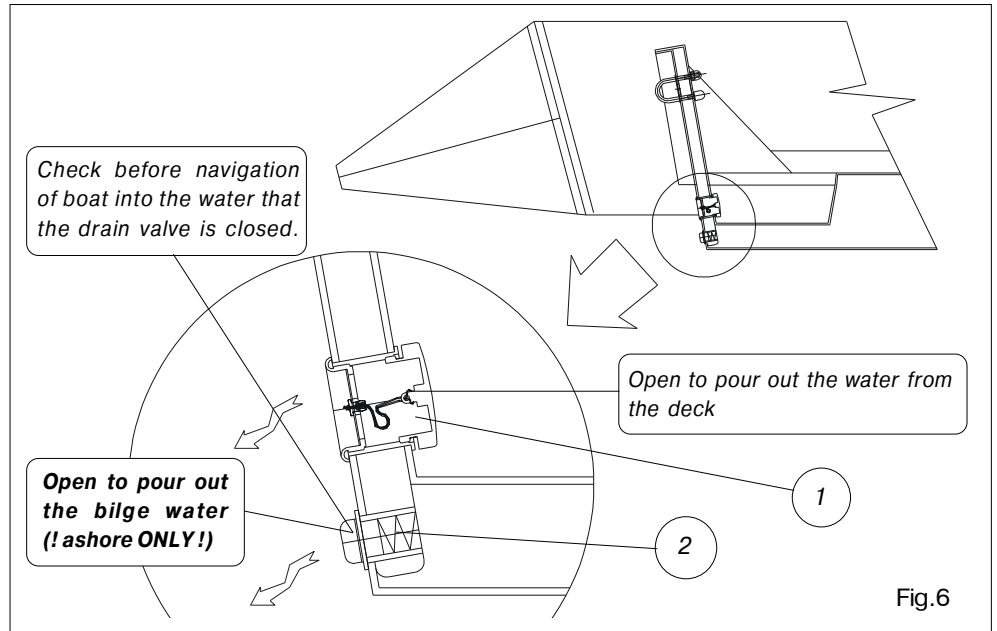
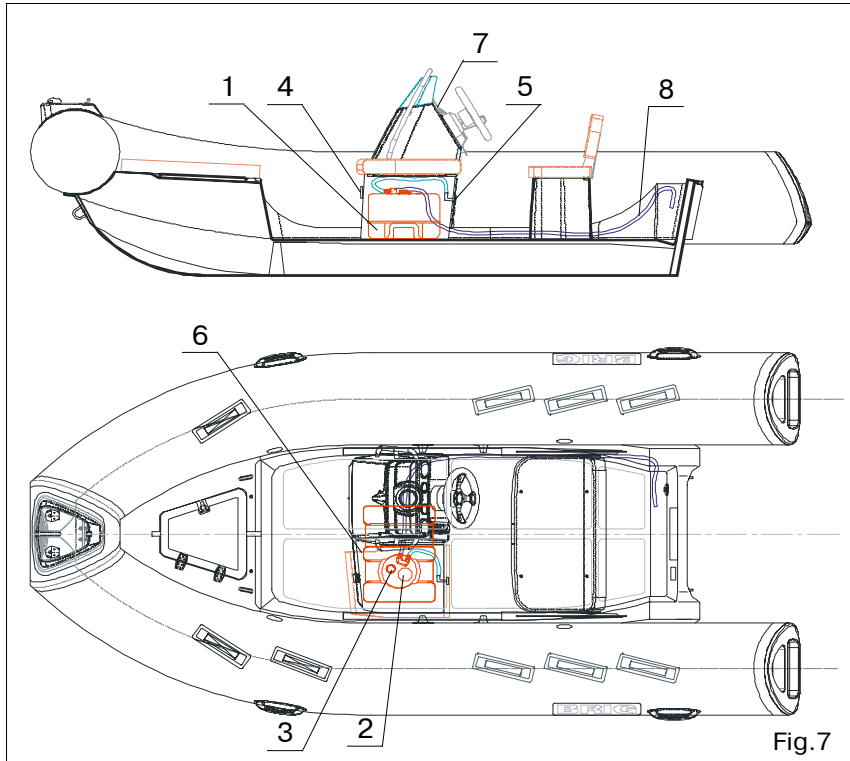

Fig.6

FUEL SYSTEM.



Fuel system for TENDER DELUXE version (Fig.7).

- 1 - Fuel tank 33L
- 2 - Fuel filling neck
- 3 - Fuel level sensor
- 4 - Ventilation holes
- 5 - Drain hose with drain pipe
- 6 - Inspection hatch
- 7 - Fuel level instrument
- 8 - Feeding fuel hose



Pre-filter and fuel valve must be installed by authorized representative specialists only.



Do not modify fuel system. Any modification, repair and planned maintenance of the fuel system may be made by authorized representative specialists only.



Always check that there are no leaks in the fuel systems



Do not smoke when refueling. Stop the engine and switch off any electric equipments before refueling.



It is dangerous to pretend to be an expert. This may cause damages. Refer to expert and authorized specialists for all types of maintenance and repair.

MAINTENANCE.

- Main conditions of long service life is right and careful servicing. Avoid excessive increasing of pressure in the board, especially from heating by the sun rays.
- After exploitation take off sand and dirt from boat surface, and carefully dry it.
- Avoid the water getting into the chambers. If a fuel or an oil gets to the boat surface it is necessary to wash the soiling place by soap water as soon as possible and dry.
- Pay attention to the condition of bottom surfaces. If it's cover is destroyed it is necessary to dry this element and restore the defend cover.
- After season prepare the boat to winter keeping. Clean boat surface from sand and dirt and make the necessary repairs, if damages take place. If it is possible, keep the boat in the open and slightly pumped state in air temperature 0-25°C. The boat must be protected from the sun rays.
- Insignificant boat repairing (eliminating the board punctures or cuts) you may carry out by yourself. In this case use the coated fabric and glue set for repair from the complete set.

Independent performance of any complex repair associated with considerable damages to the board, partitions and seams is not recommended. In such cases, apply to your dealer.

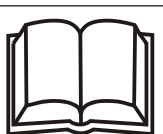

ATTENTION

Storage of the boat with temperature variations from -30°C to +45°C may be allowed for not longer than 1 month. In case the boat has being stored or transported at a temperature bellow 0°C, it must be held at a temperature above +15°C for at least 1 hour before be unpacked and unfolded.

For small repair boat tube use the coated fabric and glue set from the complete set.

OPERATING REGULATIONS.

Dear owner,



We thank your for your purchase and do hope that you will have a great fun of it. However, to make your joy and pleasure complete, we would request you to read carefully and observe the directions and recommendations specified below.



DANGER

IT IS STRICTLY FORBIDDEN to handle the boat in the state of intoxication and without individual rescue means being used (life-saving belts, jackets, etc.)

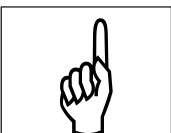
IT IS FORBIDDEN to use an outboard engine of power exceeding the maximum allowable value

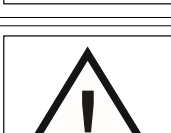
 <p>WARNING</p>	<p>IT IS FORBIDDEN to bring the tube pressure up to the value exceeding the rated one (0.15 bar(2.2pci))</p> <p>IT IS STRICTLY FORBIDDEN to drag the boat across a rough surface.</p> <p>For each particular water area the local shipping regulations are in force. You may apply for information to the appropriate water transport and shipping directorate, as well as to the water police.</p>
 <p>WARNING</p>	<p>Use the boat equipment and accessories only on their direct purpose to ensure reliable service.</p> <p>Even when sailing with an outboard engine you should always have the oars available with you so that you were able to reach the shore without outside assistance in case of any damage to the boat.</p>
 <p>WARNING</p>	<p>On your request any outboard engine seller may provide your engine with the emergency stop switch. During navigation the switch should be connected to the wrist of your hand by means of a cord. In case you fall overboard, even if being a steersman, the switch will cut out the engine and the propeller. This arrangement will enable you to avoid any traumas and to reach the boat.</p> <p>Take all possible precautions against penetration of fuel, oil or electrolyte from the storage battery into the inflatable boat. If it does happen wash thoroughly the fouled spots with water.</p>
 <p>DANGER</p>	<p>You should be always sure that the number of people on board never exceeds that specified in the owner's manual or on the builder's plate provided on the transom.</p> <p>The boat will retain an adequate floatability and will not keel over only provided that the load is arranged reasonably. Therefore, do not accommodate all passengers on the same side of the boat.</p>
 <p>DANGER</p>	<p>All passengers should be accommodated inside the boat. The occupied seats should not be left throughout the entire sailing time.</p>



DANGER

All passengers should put on life-saving jackets

CHILDREN and non-swimmers **MUST BE A FLOATATION DEVICE AT ALL TIMES.**

Always check that floatation devices for children are of the right size and that they are operational.



DANGER

Arrange the cargo to be carried uniformly inside the boat, all items being reliably secured on the bottom of the boat.

When sailing with an outboard engine the steersman should shift his body forward in the course of acceleration to prevent the boat forebody from raising under the force of upthrust waves.



WARNING

Despite the strong shell of the boat we are recommended to handle sharp and pricking objects being on board with care. For example, it concerns a knife blade, fish-hook point, etc.



DANGER

Approach rocky shores, shoals, moles, etc. carefully to avoid damages to the boat. It is strictly prohibited to drag the boat across rough surfaces (shingle, rocks, concrete, etc.).

In case of prolonged navigation with the use of an outboard engine, regularly check to ensure that the engine is reliably attached to the boat. If the engine was attached carelessly the attachment may work loose under the action of vibration.



WARNING

Besides, check air chambers pressure at regular intervals, since the pressure may vary under the effects of outside air temperature and atmospheric pressure variations.

Never forget to monitor regularly the quantity of fuel in the fuel tank. Keep always in mind that the quantity of fuel should be sufficient for you to sail to your final destination.

- **Towing**



ATTENTION

At towing the towing rope length should not be at least 3 lengths of the boat.

The steersman of the towed boat should be assisted by another crew member to monitor the process of towing. In this case, certain communication gestures should be agreed upon beforehand.



WARNING

The rope being secured to both boats in a manner ensuring its immediately, single-motion release.

- **Damage to one of air chambers**

The inflatable boat is designed to provide an adequate stability in case of the complete damage to one the air chambers (balloon compartments) at the expense of the remaining air chambers and the hull. Thanks to it, you will be able to reach safely the nearest shore. Reduce the speed and shift your body to the undamaged part of the boat. Watch changes in stability. After this immediately head for the nearest shore. To prevent penetration of water into the boat, pull the shell of the damaged air chambers upwards.

- **Anchor and mooring fast fastening**



WARNING

Fix the anchor and towing ropes in the bow of the boat to the front towing ring. Fix the back anchor ropes to the back towing ring.

- **Danger of currents and wind**





DANGER

Before navigation of the boat make detail inquiries about local conditions and regulations! Currents, wind, shoals, rising and falling tides, as well as weather variations may imply serious danger!

● **In emergency stay in boat**

In any unexpected situation (engine failure, boat damage, etc.) do not ever leave the boat provided it is still afloat. Even if you believe that the shore is just nearby stay in the boat, since you will be looked for in this particular place and, most probably, will be found. Should the boat become partially flooded throw heavy objects (batteries, fuel tank, engine) overboard to ensure additional floatability.

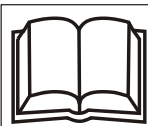
● **Handling under power**

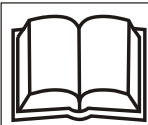
 <p>WARNING</p>	<p>Sudden turn may cause loss of control. Reduce speed before making sharp in either direction.</p>
 <p>ATTENTION</p>	<p style="text-align: center;">Maximum propulsion power rating for the boats:</p> <p style="text-align: center;">F380 - 37 kW (50 HP) F420 - 45 kW (60 HP) F480 - 56 kW (75 HP)</p> <p>When the boat is fitted with an engine with maximum recommended power it must be use with extreme care. This application is directed at experienced users using their boats for very specific purposes.</p>
 <p>WARNING</p>	<p>Do not operate your boat with an engine of rated power larger than that posted on the builder's plate in the boat.</p>
 <p>ATTENTION</p>	<p>Do not operate this craft at negative propulsion unit trim settings (bow down) at high speed. Craft may lean over on side. Instability in turns may result. Use negative trim to accelerate to planing speed from displacement speed and at lower planing speeds in choppy water (applicable to craft equipped with propulsion unit power trim).</p> <p>Do not operate at maximum speed while in congested high traffic waterways or in weather and sea conditions of reduced visibility high winds or large waves. Reduce speed and wake as a courtesy and as a safety consideration to yourself and others. Observe and obey speed limit and no wake zones.</p> <p>Observe right-of-way as defined by Rules of the Road and required by COLREG.</p> <p>Always be certain to have sufficient distance to stop or manoeuvre if required to avoid collisions.</p>

●REBOARDING MEANS.

All persons on board should always be in life jackets.

Before starting the motor, make sure that the safety pin is used.

If you are in the water, you can return on board.

To do this, there are handles (Fig.1 (7)) on the boat tube that you can use to get back on board.

Boats of this model have a low freeboard.

The manufacturer does not complete the boat of this model with other reboarding means.

However, you can additionally order from your dealer other means to return on board.

Contact your dealer if necessary.

● **WARNING SIGNS AND LABELS.**

In accordance with ABYC standards, warning signs and labels are installed on your boat (if applicable).

Do not remove warning signs and labels. Always check their suitability.

If the warning signs are damaged and you cannot read the text or symbols, you must order new ones from your dealer.

Check with your dealer for the correct warning signs and labels mounting location.

BOAT CAPACITY LABEL.

Place of installation: on a boat transom

F380



F420

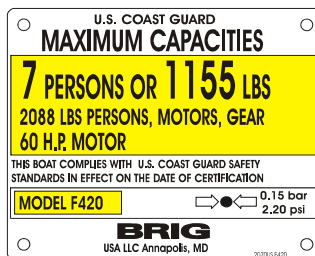

F480



WARNING. MAXIMUM ENGINE WEIGHT.

Place of installation: on the hull of the boat near the outboard engine.

F380

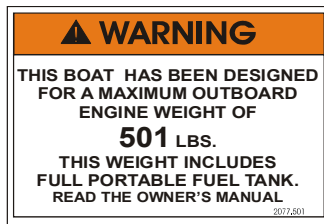

F420

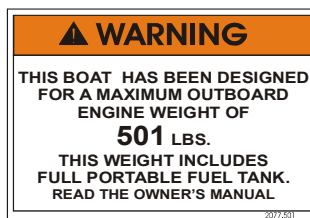

F480



WARNING. LEAKING FUEL

Place of installation: on the hull near of the fuel filler.

All models.



WARNING. ROTATING PROPELLER

Place of installation: from the outside of the boat transom.

All models.

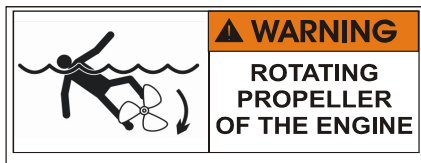

WARNING. FAILURE TO FOLLOW THESE WARNINGS COULD CAUSE SEVERE INJURY OR DEATH



Place of installation: on the steering console.

All models.

▲ WARNING

Failure to follow these warnings could cause SEVERE INJURY or DEATH

- **CARBON MONOXIDE (CO) CAN CAUSE BRAIN DAMAGE OR DEATH.**
 - Engine and generator exhaust odorless and colorless carbon monoxide gas.
 - Signs of carbon monoxide poisoning include nausea, headache, dizziness, drowsiness, and lack of consciousness
 - **MOVE TO FRESH AIR** if anyone shows signs of carbon monoxide poisoning.
- **CHECK WEATHER FORECAST BEFORE DEPARTING DOCK** and heed all weather advisories
- **WEAR SAFETY LANYARD** at all time while operating boat to prevent unmanned operation.
- **NEVER OPERATE WHILE UNDER THE INFLUENCE** of drugs or alcohol.
- **DO NOT OVERLOAD THE BOAT. ENSURE THAT WEIGHT IS PROPERLY AND EVENLY DISTRIBUTED** fore and aft and on both side of the boat to avoid poor handling, sudden loss of control, swamping and/or capsizing.
- **PASSENGERS SHOULD WEAR U.S. COAST GUARD APPROVED LIFE JACKETS.**
- **MAKE SURE THAT ALL PASSENGERS ARE PROPERLY SEATED WHILE UNDERWAY.** To avoid passengers falling overboard or being ejected from the boat, do not allow passengers to sit on seat backs, gunwales or outermost deck edges while boat is moving.
- **REDUCE SPEED BEFORE ATTEMPTING SUDDEN OR SHARP TURNS, AND MAINTAIN SAFE SPEEDS** for water conditions and environment at all times. Maneuverability at high speeds is limited, and sudden turns may cause loss of boat control.
- **KEEP PROPER LOOKOUT AND SAFE DISTANCE** for the conditions at all time to avoid collisions.
- **OBEY APPLICABLE NAVIGATION RULES AND BOATING LAWS.**
- **USE CAUTION AND PROPER LIGHTING** during night time and boating in adverse weather.
- **READ THE OWNER'S MANUAL AND COMPLETE THE BOAT'S PRE-OPERATION CHECKLIST** prior to boat operation.



NOTE: The inflatable boat was delivered with the following equipment installed:

1.Fuel tank	Stamp and signature	
2.Electric system	Stamp and signature	
3.Drain system	Stamp and signature	
4.Bilge pump	Stamp and signature	
5.Steering system	Stamp and signature	
6.Engine power system	Stamp and signature	
7.Engine installation, test and completion of plants and fittings done by	Stamp and signature	



MODEL

SERIAL No.

UA-QRK

Date of manufacture

Quality inspection stamp